

HIGH SPIN INDUSTRIAL WASHER EXTRACTORS



FS
RANGE

FS 800 FS 1000 FS 1200

80KG 100KG 120KG
180LB 230LB 275LB



FEATURES

- Freestanding, high spin washer
- Stainless steel cabinet
- Stainless steel drum and tub
- Extra large door opening (FS800, FS1000 Ø 530 mm, FS1200 Ø 650 mm)
- Two large drain valves (Ø 103 mm)
- Easy access to all parts
- USB plug located on the main board
- Standard liquid soap connections
- Frequency controlled motor
- PowerWash® perforated lifting ribs: more mechanical action, lower water consumption
- Air operated water inlet
- SuperEco washing programmes significantly reduces water and electricity consumption
- Patented soap dispenser with 5 removable compartments
- Manual weighting system

XCONTROL FLEX PLUS PLATFORM

- 7" Touch intuitive programmer
- Available in 34 languages
- Factory built wifi for programming and updating
- Service alerts for easy maintenance
- Fully programmable
- 20 preset programs, up to 99 in memory
- Combine with Trace-Tech™ and i-Trace laundry management softwares for a perfect control of your laundry installation.



XControl FLEX PLUS approach, program, and cycle screens

OPTIONS

- Liquid soap pumps
- Forward and backward tilting is available. Tilting of the machine is done by external platform



ROBUST DESIGN



LARGE DOOR OPENING



TOUCH SCREEN CONTROLS



GET AHEAD IN LAUNDRY

*Consult your sales representative for availability

TYPE		FS800	FS1000	FS1200
CAPACITY				
Drum volume	l	807	972	1154
Capacity 1:10	kg/lb	80/176	97/214	115/253
Capacity 1:9	kg	89/196	108/238	128/282
Drum diameter	mm	Ø 1110	Ø 1200	Ø 1300
MOTOR				
Frequency controlled		standard	standard	standard
DRUM SPEED				
Wash speed	rpm	36	33	32
Spin speed	rpm	750	720	695
G-Factor		350	350	350
PROGRAMMER				
XControl FLEX PLUS microprocessor		standard	standard	standard
CABINET				
Stainless steel AISI 304		standard	standard	standard
DRUM				
Stainless steel AISI 304		standard	standard	standard
HEATING				
Electrical	kW	67,5	-	-
Steam high pressure	bar	3-8	3-8	3-8
	psi	44-116	44-116	44-116
CONNECTION				
Electrical		3x380-480V 50/60Hz 3x208-240V 50/60Hz, 3x 440-480V 50/60Hz		
	kW	11,25	15,25	18,75
Water inlet	inch	3x1 1/2"	3x1 1/2"	3x1 1/2"
Steam inlet	inch	1"	1"	1"
Compressed air inlet	mm	Ø 8	Ø 8	Ø 8
Drain	mm	2x103 2x4"	2x103 2x4"	2x103 2x4"
DIMENSIONS				
H×W×D	mm	1985×1495×1940	2060×1790×2005	2085×1855×2085
Net weight	kg	2640	3170	3480
TRANSPORT DATA				
Volume (packed)	m³	7,25	9,29	10,16
Packed H×W×D	mm	2200x1690x1950	2345x1865x2125	2340x2000x2170
Gross weight	kg	2830	3410	3710

- = Not available

Standard = Standard execution, The data concerning dimensions of machines include all extended parts

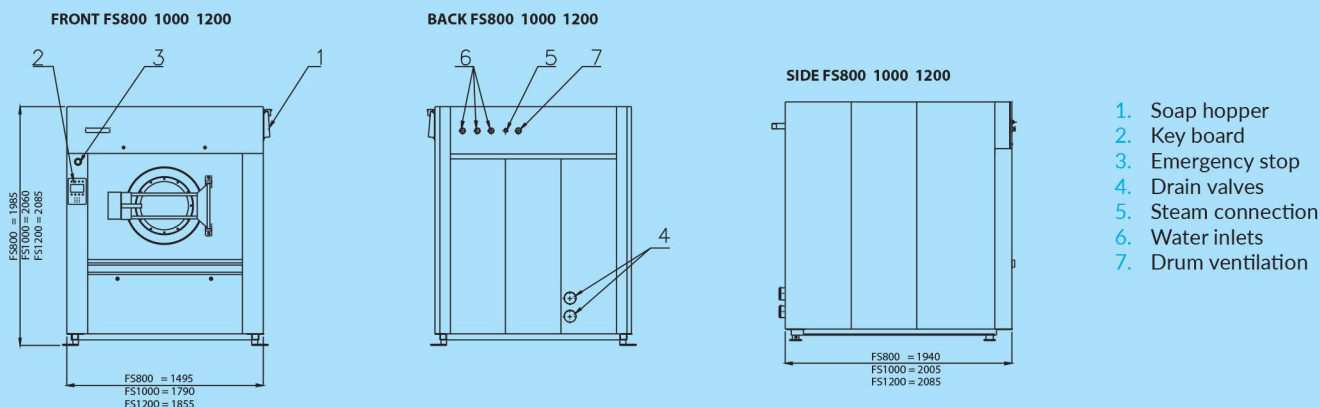

FS MODELS WITH FORWARD TILTING OPTION

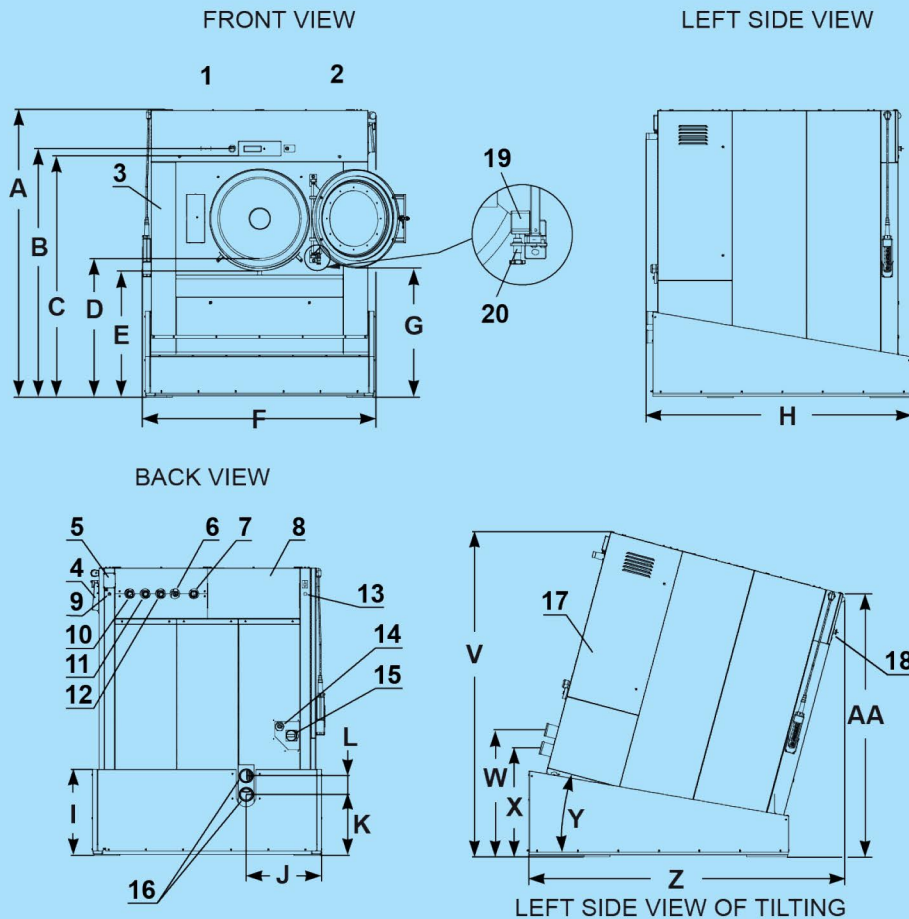

SPECIFICATION	FS800 (mm)	FS1000 (mm)	FS1200 (mm)
A	2215	2300	2335
B	1908	2004	2015
C	1850	1946	1957
D	1037	1158	1149
E	988	1062	1048
F	1565	1855	1895
G	1019	1095	1082
H	2020	2100	2155
I	705	695	695
J	468	610	610
K	491	511	492
L	155	155	155
V	2476	2575	2628
W	983	1027	1028
X	837	881	882
Y	15°	15°	15°
Z	2380	2534	2553
AA	2009	2098	2124

1. Box of electrical components
2. Soap dispenser ventilation
3. Control panel
4. Soap dispenser
5. Electrical signals liquid soap
6. Steam inlet
7. Tub ventilation
8. Cover for pneumatic components
9. Hose connection soap supply
10. Hard cold water inlet
11. Soft cold water inlet
12. Hot water inlet
13. Compressed air inlet
14. Entry main power cable
15. Main switch
16. Drain outlet
17. Electric switchboard cover
18. Serial label
19. Door securing finger backstop
20. Finger complete

*Consult your sales representative for availability