

HIGH EFFICIENT RIGID MOUNTED INDUSTRIAL WASHER EXTRACTORS

RX
RANGE

RX 180

20kg

RX 240

27kg

RX 280

32kg



FEATURES

- Rigid mounted, normal spin, 100 G-factor
- Stainless steel top panel & Anthracite grey front and side panels
- Stainless steel drum and tub
- Xcontrol - easy to use microprocessor
- Patented Soap Hopper
- High capacity water inlets (RX280)
- Large drain valve (Ø 76 mm)
- Easy access to all vital parts from the front
- Large door opening for easy loading & unloading

OPTIONS

- 200 G-factor execution
- Xcontrol Plus - Fully programmable
- Coin operated timer (CPS)
- Stainless steel front and side panels
- USB+ RS485 plug (on the back panel)
- Easy Soap - liquid soaps connection
- Liquid soap pumps
- Water recovery kit
- Steam heating version
- 3rd water inlet
- High capacity water inlets (RX180, 240)
- 7 mm drum perforation (RX180-240)
- IP44 protection



ERGONOMICAL
CONSTRUCTION



LARGE DOOR
OPENING



LOW WATER
AND ENERGY
CONSUMPTION

cascade
drum

TRACE-TECH

POWERWASH

XCONTROL+

supereco

| TYPE | | RX180 | RX240 | RX280 |
|------------------------------|------------|------------------------|------------------------|------------------------|
| INNERDRUM | | | | |
| maximum capacity 1:9 | kg | 20 | 27 | 32 |
| capacity 1:10 | kg | 18 | 24 | 28 |
| volume | litres | 180 | 240 | 280 |
| diameter | mm | 750 | 750 | 750 |
| DRUM SPEED | | | | |
| wash | rpm | 42 | 42 | 42 |
| extraction | rpm | 490 (690)* | 490 (690)* | 490 (690)* |
| G-FACTOR | | | | |
| | | 100 (standard) 200* | 100 (standard) 200* | 100 (standard) 200* |
| HEATING | | | | |
| electricity (standard) | kW | 12 / 18 | 18 | 18 / 21,9 |
| steam | bar | 1-8 | 1-8 | 1-8 |
| hot water | °C | 90 | 90 | 90 |
| Sound pressure level | dB (A) | < 65 | < 65 | < 65 |
| Water valves connection | BSP | 3/4" | 3/4" | 3/4" |
| Water pressure | kPa | 100-800 | 100-800 | 100-800 |
| Rec. water pressure | kPa | 300-500 | 300-500 | 300-500 |
| Water inlet | l/min | 20 | 20 | 20 |
| Drain valve | outer Ø mm | 76 | 76 | 76 |
| Flow amount with drain valve | l/min | 210 | 210 | 210 |
| Steam valve connection | BSP | 1/2" | 1/2" | 1/2" |
| Steam pressure | kPa | 100-800 | 100-800 | 100-800 |
| DIMENSIONS | | | | |
| Size HxWxD | mm | 1410x890x915 | 1410x890x1060 | 1410x890x1135 |
| Net weight | kg | 255 (315)* | 275 (330)* | 290 (355)* |
| TRANSPORT DATA | | | | |
| Packed HxWxD | mm | 1550x925x970 | 1550x925x1130 | 1550x925x1190 |
| Gross weight | kg | 270 (335)* | 290 (355)* | 305 (385)* |

* 200 G-factor execution

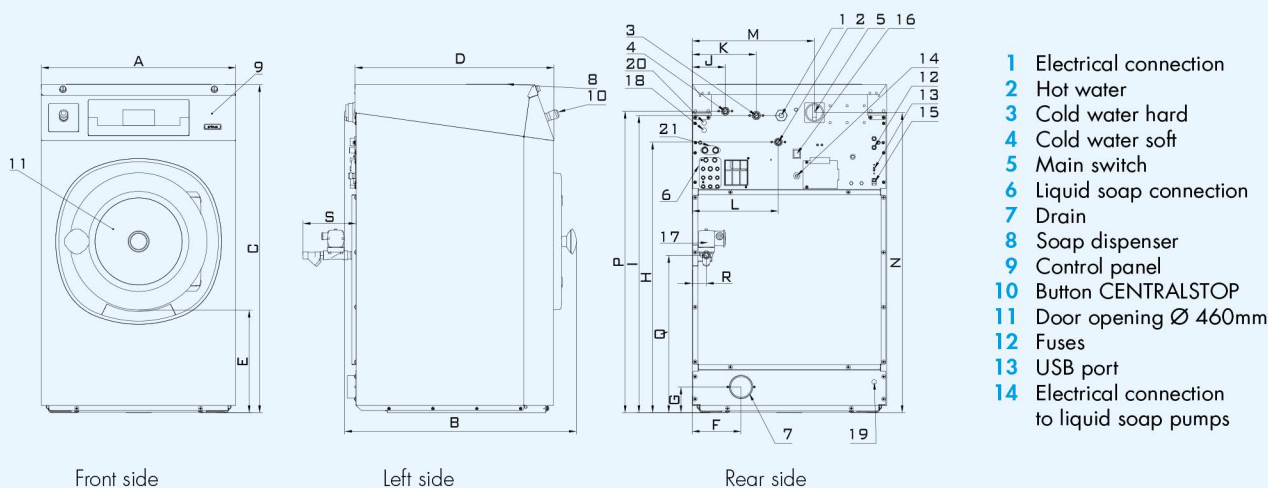

DIMENSIONS

| | A | B | C | D | E | F | G | H | I | J | K | L | M | N | P | Q | R | S |
|-------|-------------|------|--------|------|-----|-----|-----|------|------|-----|-----|-----|-----|------|------|-----|----|-----|
| RX180 | 890 | 915 | 1410 | 815 | 465 | 280 | 130 | 1212 | 1297 | 113 | 218 | 303 | 625 | 1270 | 1317 | 528 | 54 | 120 |
| RX240 | 890 | 1060 | 1410 | 960 | 465 | 280 | 130 | 1212 | 1297 | 113 | 218 | 303 | 625 | 1270 | 1317 | 528 | 54 | 120 |
| RX280 | 890 | 1135 | 1410 | 1035 | 465 | 280 | 130 | 1212 | 1297 | 113 | 218 | 303 | 625 | 1270 | 1317 | 528 | 54 | 120 |
| | width depth | | height | | | | | | | | | | | | | | | |

VISIT OUR WEBSITE www.totalce.com.au
 CALL US ON 1300 355 769



Complete Project Solutions™



The Primus preserves the right to change the machines and the specification in this leaflet at any time, without prior notice. Details and photographs are only for information and never binding.

www.primuslaundry.com

