

TopLine

Safety and reliability right down the line



TopLine in detail

TopLine – More than just technology

Type 'AA' air gap according to DIN EN 1717

MIKE 2 electronic control system

Proximity switch to operate door (optional)

Nozzle system for intensive cleaning

Deep-drawn wash chamber, self-cleaning

Powerful telescopic rotary jet

Siphon monitoring system

HEPA filter (H13)

Foot switch to operate door (optional)

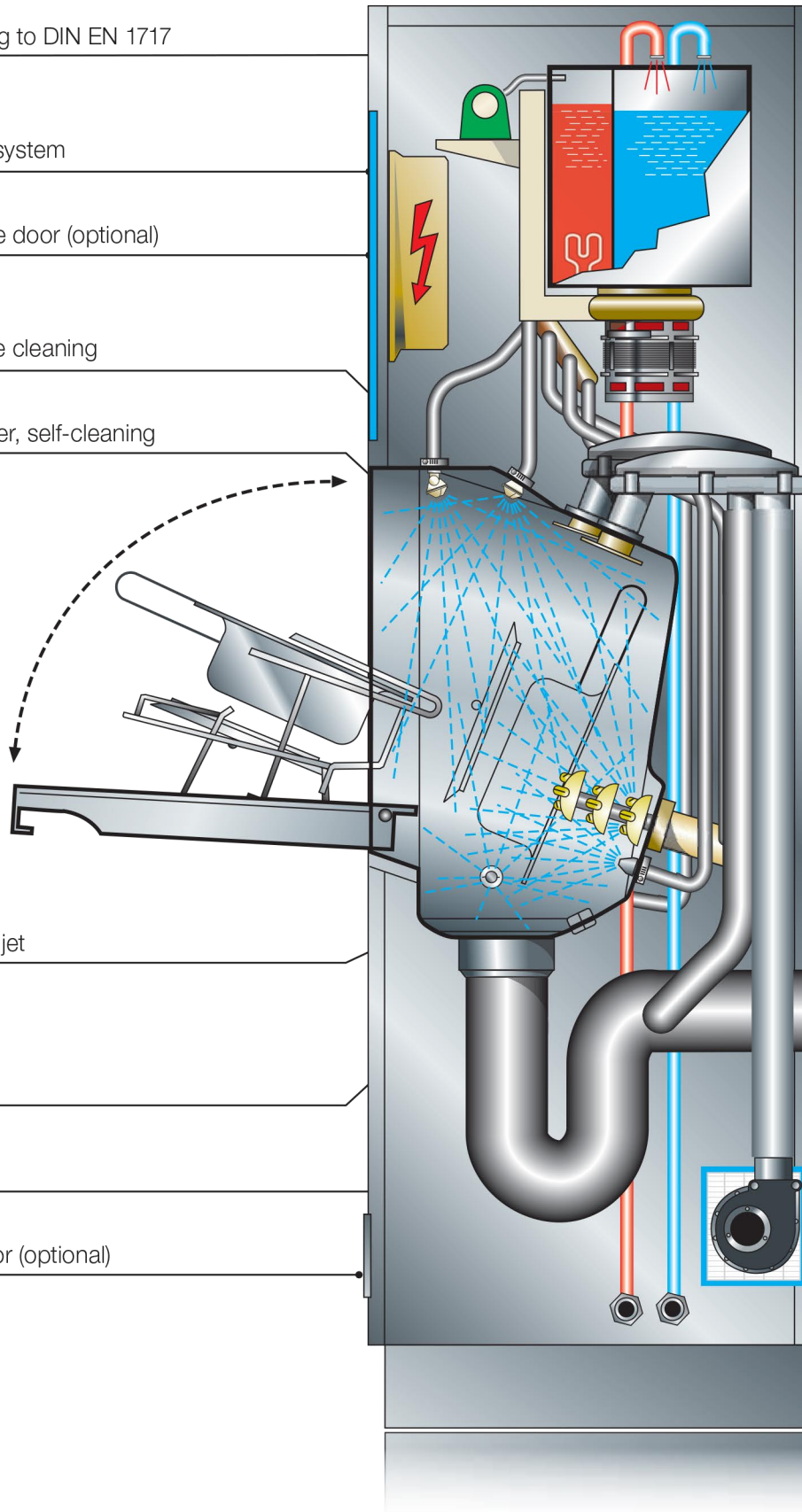

Safety you can rely on



Today, more than ever, strict hygiene standards are an absolute must in healthcare environments and patient welfare and safety are a primary concern.



MEIKO TopLine cleaning and disinfection appliances give you the reassurance of top-notch safety and reliability right down the line. From effective reprocessing of care utensils to reliable, user-friendly operation, the *TopLine* range features

impressive technology that ensures the safety of both patients and care personnel while adhering strictly to the requirements of DIN EN ISO 15883. Check out some of the highlights of MEIKO technology – and discover the key benefits of our *TopLine* machines.

Delivering added value through innovative solutions



Steam Stop

Optimises hygiene and safety with a patented design which ensures that no steam escapes from the system.

Power Clean

Gets every last spot of your care utensils hygienically clean with a powerful telescopic rotary jet and an optimised wash system that acts on all sides.

Thermo Control

Takes reliable disinfection to the next level by offering patented control of the freely selectable* A₀ value, carefully monitored by temperature sensors which cross-check each other's readings.

*from 60 to 3000.

Dry&Cool

Uses filtered air to dry and cool, producing hygienically clean care utensils that are cool to the touch.



T.A.D.

Chem Code

Ca²⁰ Stop

The *Total Auto Disinfection (T.A.D.)* function disinfects all the water pipes in the machine after each completed wash cycle to avoid the risk of re-contamination.

Uses a unique suction lance coding system to eliminate the risk of mixing up rinse aid and detergent and to ensure a validated process.

Guarantees high operating reliability by using sensors to monitor dosing of the detergent and of the softener/rinse aid mix.

MEIKO's TopLine range is available in a wealth of different designs and configurations. From individual floor standing and wall-mounted appliances to units designed to be incorporated in patients' bathrooms, and from practical appliances installed under work surfaces to compact combined care units, TopLine offers versatile options for every type of dirty utility room. So you can be sure of getting a tailor-made solution that meets your needs. You can find more information on the available options in our latest MEIKO TopLine product brochure.



TopLine 10

For off-the-floor wall mounting. Basic model. Compact and ready to connect.



TopLine 20

Cleaning and disinfection appliance with plinth. Simply place in position and connect up. The ideal way to make the best use of existing connections.

TopLine floor standing unit

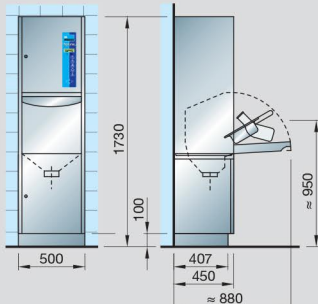

TopLine small combined care unit

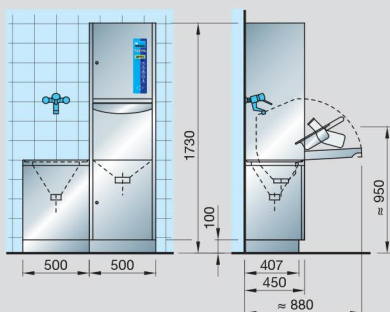

TopLine unit for under work surfaces

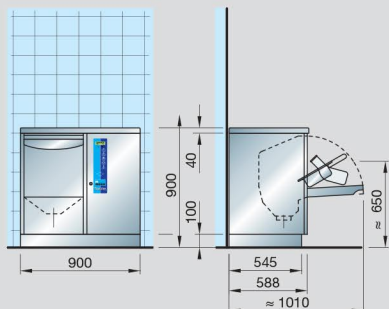

SAN 14 B

Compact combined care unit consisting of TopLine 40, slop sink, washbasin and storage surface. Includes splash screen and upstand.



SAN 20 W

Combined care unit with 600 mm cupboard space. Consists of TopLine 40, slop sink, washbasin and storage surface. Includes splash screen and upstand.



Total
Commercial Equipment
Complete Project Solutions™

Phone 1300 355 769

enquiries@totalce.com.au

www.totalce.com.au

The MEIKO team will be more than happy to help you find the clean solution that meets the specific hygiene standards required in your work environment. Just give us a call!